

# Clutch Master Cylinder

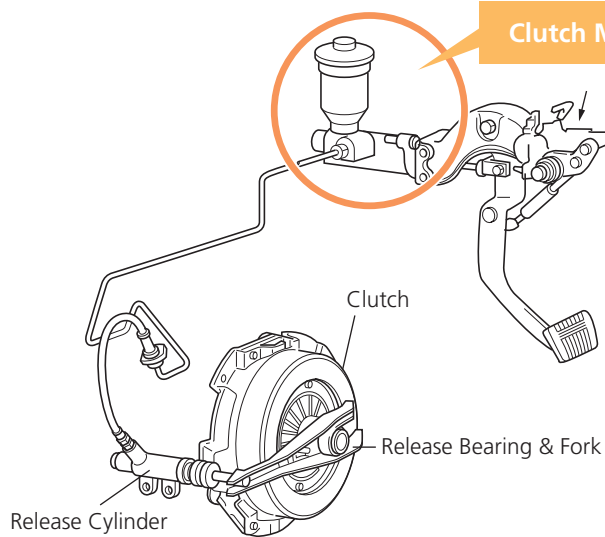

## Function



The clutch master cylinder is a device that transforms mechanical force into hydraulic pressure. As the driver presses the clutch pedal, the pedal lever applies force to the clutch master cylinder which transmits hydraulic pressure to the clutch release (slave) cylinder that disconnects engine power to the transmission.

## Structure and Components

### [Conventional Type]

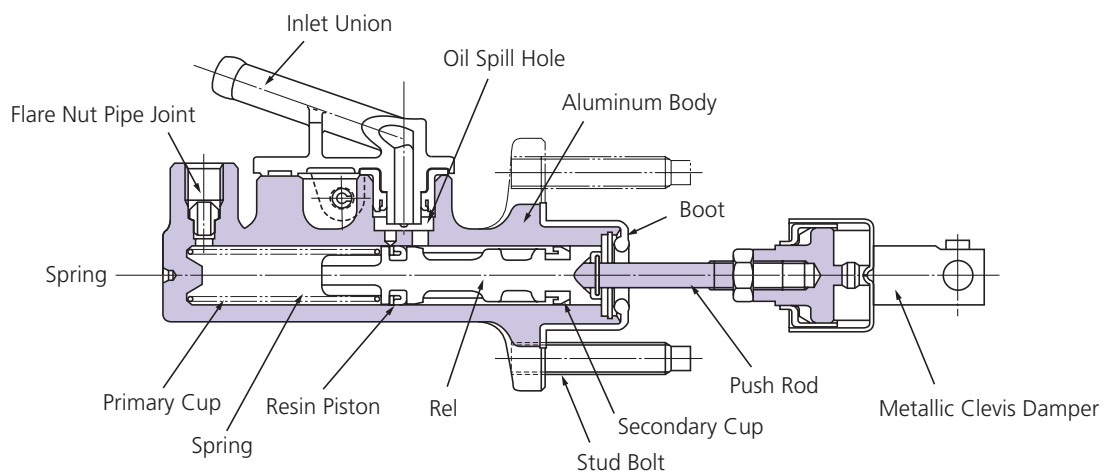

The clutch master cylinder structure consists of the piston, cups, and springs, built within a precision machined body. The primary cup, positioned on the leading side of the body, functions to create hydraulic pressure when fluid is forced inside by the piston. Located on the trailing side is the secondary cup, which guides the piston and prevents fluid from leaking. When the clutch pedal is pressed, the primary cup is blocked away by the piston from the oil spill port leading to the reservoir tank, pressure in the cylinder rises as the fluid is fed through the pipeline. When the clutch pedal is released, the hydraulic pressure and the force of the return spring pulls back the piston to relieve fluid back into the reservoir. The clutch master cylinder is what provides the necessary force to control the application of drivetrain power.

# Variations

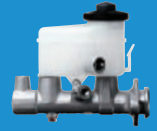

## Clutch Master Cylinder Variations

- Conventional Port-less Type
- Stand Alone / Integrated Reservoir Type
- Types With and Without Stud Bolts
- Types With and Without Clevis Damper
- Types With and Without Clutch Booster

### [Stand Alone Reservoir Type]

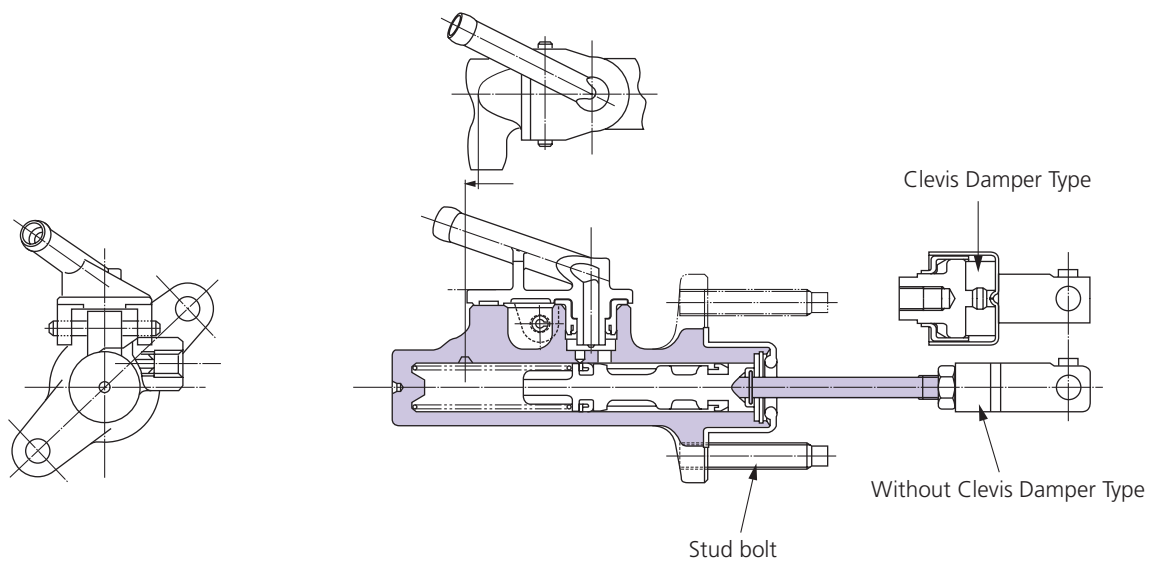

### [Integrated Reservoir Type]

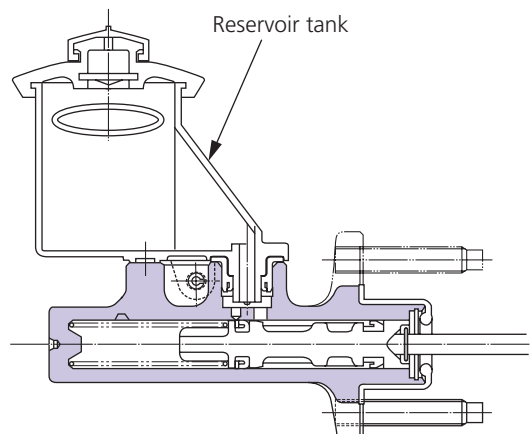

# Installation Procedure

**CAUTION!** Failure to follow recommended procedures may cause clutch failure and injury. Always consult the manufacturer's vehicle specific service manual for reference.

1

Do not allow dust, dirt, and debris to enter the cylinder or reservoir tank.

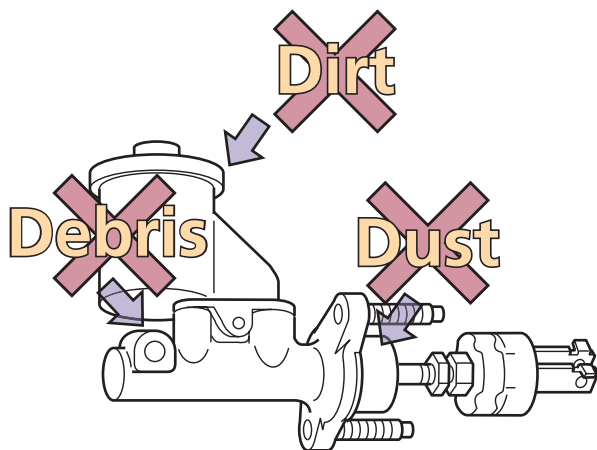

Internal damage may occur, resulting in fluid leakage and improper hydraulic pressure.

2

Always use vehicle manufacturer specified fluid.

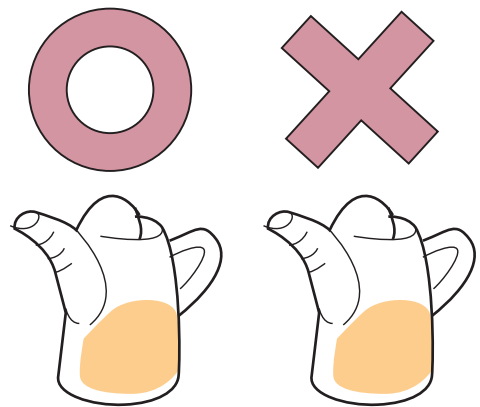

Specified brake fluid    Other brake fluids

Sealing can be impaired if mineral additives are mixed with fluid which can cause clutch failure.

3

Tighten bolts, nuts, and screws as specified by the manufacturer's vehicle specific manual.

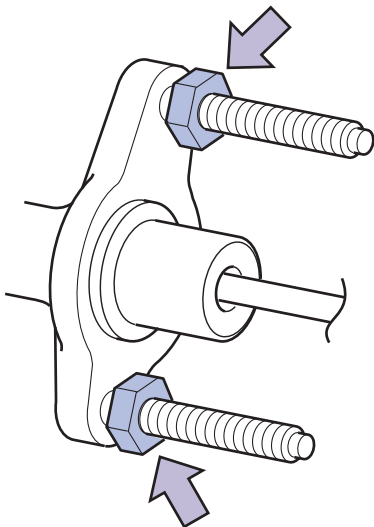

Damage of screws and threads may cause improper function.

4

Adjust the clutch pedal lever according to the method specified by the manufacturer's vehicle specific manual.

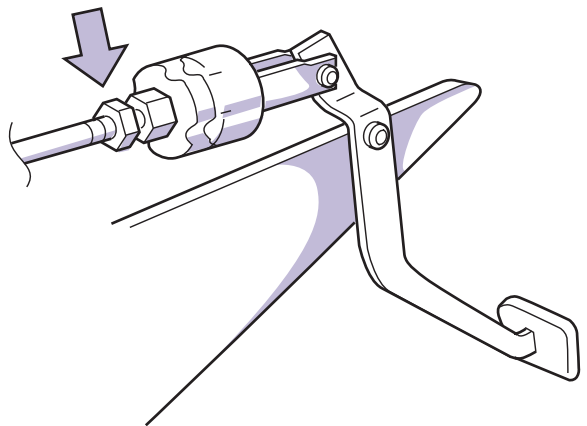

Improper adjustment will cause poor clutch engagement and release.

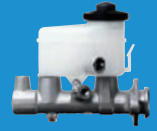

**CAUTION!** Failure to follow recommended procedures may cause clutch failure and injury. Always consult the manufacturer's vehicle specific service manual for reference.

5

Handle with care. Clutch master cylinders are precision manufactured. Do not drop or deform. Never use a damaged unit.

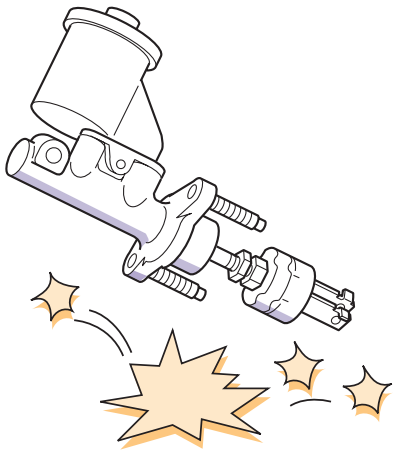

Optimal hydraulic pressure may not be achieved due to damaged internal parts, resulting in incorrect operation and injury.